

TPS Pallet Truck Scales

General Specifications

- Display 52mm LCD display, attached white color LED display
- Capacities 1t, 2t
- Keyboard 7 keys(Mechanical keyboard)
- Housing Mild steel
- Max. Divisions 2,000e; 4,000d
- ADC Sigma delta
- ADC update $\leq 1/10$ second
- Operate Temp $-10^{\circ}\text{C} \sim +40^{\circ}\text{C}$
- Power AC adapter(12V/500mA), Internal rechargeable battery (lead acid 6V/10Ah)

- Gross Weight 160kg
- Packing (Wide Fork) carton packing, dimension 0.82m^3 , 40 feet container can load 56 machine, 20 feet container can load 28 machine
(Narrow Fork) carton packing, dimension 0.60m^3 , 40 feet container can load 80 machine, 20 feet container can load 40 machine



- Instant weight readings are available as soon as the forks are raised
- Application: 1. Weighing units conversion 2. Net/gross shift 3. Pre-tare
- OIML approval from Delta(approval no.:DK0199.166)
- Easy access junction box
- Rugged construction for long life
- Rechargeable battery provide up to 60 hours of continuous use (without backlight)
- Built-in thermal printer(TPS-II)
- Without thermal printer(TPS-I)
- Optional initial-verification



TPS Pallet Truck Scales

Model Name	Capacity	Readability	Division	Approx. weight	Approval
TPS-I-1t	1t	0.2kg	5,000d	160kg	CE
TPS-I-2t	2t	0.5kg	4,000d	160kg	CE
TPS-I-2tM	2t	1kg	2,000e	160kg	CE, OIML
TPS-II-1t	1t	0.2kg	5,000d	160kg	CE
TPS-II-2t	2t	0.5kg	4,000d	160kg	CE
TPS-II-2tM	2t	1kg	2,000e	160kg	CE, OIML

Dimensions(mm)

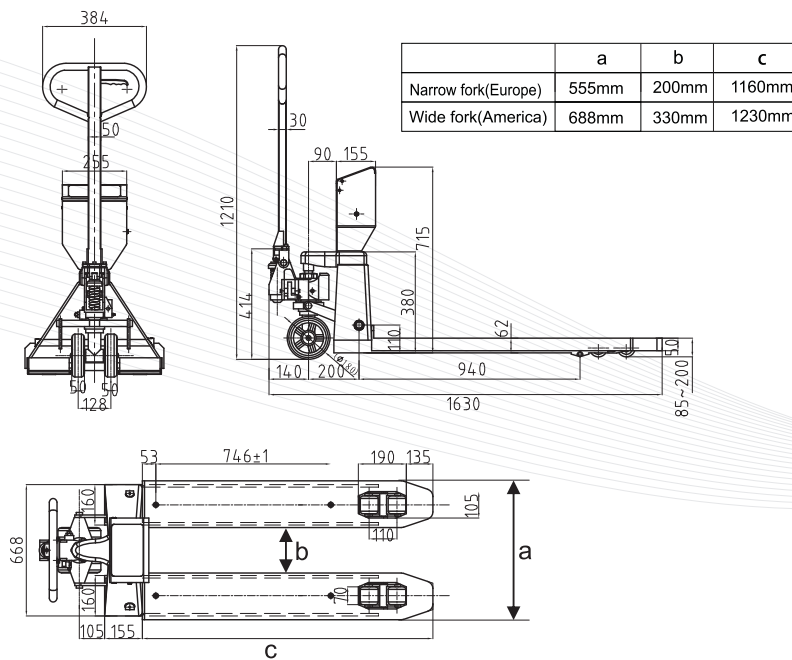

Print formats

3	61.6kg
3	61.6kg
No.	4
G.W.	61.6kg
N.W.	61.6kg
No.	5
N.W.	61.6kg
TOTAL	369.4kg
No.	6
Time	11:44:03
Date	2026/03/30
Date	2026/03/30
Time	11:43:28
No.	6
N.W.	61.4kg
TOTAL	369.4kg
Date	2026/03/30
Time	11:40:20
	61.6kg