

General Specifications

- Display 1.2" LED display or 25mm LCD display with LED backlight
- Capacities 600kg~10t
- Keyboard 4 keys (Mechanical switch)
- Housing Die-cast aluminum
- Max. Divisions 6,000d
- ADC Sigma delta
- ADC update $\leq 1/10$ second
- Operating Temp. $-10^{\circ}\text{C} \sim +40^{\circ}\text{C}$
- Power AC adapter (12V/500mA), Internal rechargeable battery (lead acid 6V/10Ah)



- Programmable to meet customer needs
- Applications: 1. Tare 2. Hold 3. Weighing unit conversion
- SGS 300% safety approval
- Battery provides up to 60 hours of continuous use (without backlight)
- Optional hand held remote control device



TM Crane Scales

| Model Name | Capacity | Readability | Division | Approx. weight | Approval |
|------------|----------|-------------|----------|----------------|----------|
| TM-600kg | 600kg | 0.1kg | 6,000d | 14kg | CE, GS |
| TM-1t | 1t | 0.2kg | 5,000d | 14kg | CE, GS |
| TM-2t | 2t | 0.5kg | 4,000d | 16kg | CE, GS |
| TM-3t | 3t | 0.5kg | 6,000d | 18kg | CE, GS |
| TM-5t | 5t | 1kg | 5,000d | 22.5kg | CE, GS |
| TM-10t | 10t | 2kg | 5,000d | 35kg | CE, GS |

Options

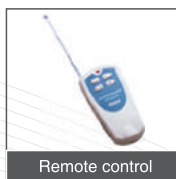

Dimensions(mm)

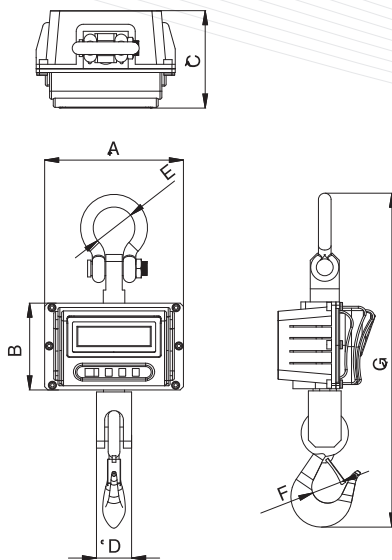

| | A | B | C | D | E | F | G |
|-----|-----|-----|-----|----|----|------|-----|
| 1t | 270 | 173 | 192 | 50 | 68 | 51 | 582 |
| 2t | 270 | 173 | 192 | 50 | 68 | 51 | 582 |
| 3t | 270 | 173 | 192 | 60 | 74 | 63.5 | 680 |
| 5t | 297 | 185 | 233 | 75 | 74 | 63.5 | 715 |
| 10t | 297 | 185 | 233 | 93 | 92 | 76.2 | 815 |