

AHW Weighing Scales

General Specifications

- Display 24mm digit LCD display, with white LED backlight
- Capacities 3kg~30kg
- Platform size 230 x 300mm
- Keyboard 7 keys(Membrane keyboard)
- Housing ABS plastic
- Max. Divisions 3,000e; 2 x 3,000e; 30,000d; 60,000d
- ADC Sigma delta
- ADC update $\leq 1/10$ second
- Operate Temp $-10^{\circ}\text{C} \sim +40^{\circ}\text{C}$
- Power AC adapter (12V/500mA), internal rechargeable battery (6V/4Ah)
- Gross weight 5kg



- Applications: 1. Check weighing 2. Counting 3. Percentage 4. Accumulation 5. Weighing units conversion
- Check weighing (user can set hi/low limit for weighing, counting and percentage)
- OIML approval from NMI (approval no.:T7305)
- Battery provides up to 70 hours of continuous use (without backlight)
- Optional RS-232 can connect to computer or printer
- Optional rear display
- Optional initial-verification



AHW Weighing Scales

Model Number	Capacity	Readability	Division	Approx. weight	Approval
AHW-3K	3kg	0.1g	30,000d	5kg	CE
AHW-6K	6kg	0.2g	30,000d	5kg	CE
AHW-15K	15kg	0.5g	30,000d	5kg	CE
AHW-30K	30kg	1g	30,000d	5kg	CE
AHW+-3K	3kg	0.05g	60,000d	5kg	CE
AHW+-6K	6kg	0.1g	60,000d	5kg	CE
AHW+-15K	15kg	0.2g	60,000d	5kg	CE
AHW+-30K	30kg	0.5g	60,000d	5kg	CE
AHW-3K-M	3kg	1g	3,000e	5kg	CE, OIML
AHW-6K-M	6kg	2g	3,000e	5kg	CE, OIML
AHW-15K-M	15kg	5g	3,000e	5kg	CE, OIML
AHW-30K-M	30kg	10g	3,000e	5kg	CE, OIML
AHW-6K-MR	6kg	1g/2g	2x3,000e	5kg	CE, OIML
AHW-15K-MR	15kg	2g/5g	2x3,000e	5kg	CE, OIML
AHW-30K-MR	30kg	5g/10g	2x3,000e	5kg	CE, OIML

Options



Dimensions(mm)

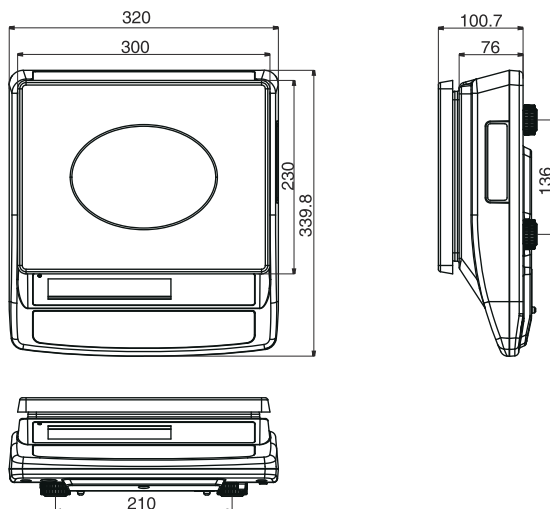

Print formats

